

EC24/B

FEATURES

- Make all your favorite coffee drinks

- Uses whole-bean and pre-ground coffee

- Coffee made to size, from 1 oz. to 12 oz.

- Built-in burr grinder with 13 grind settings

- No plumbing needed

- Rigorously tested in our U.S. manufacturing facilities for decades of use

- Exceptional 24/7 support from our Customer Care team in Madison

- Auto-descale reminders

- Five strength settings

- Hot water on demand

- Press Double Coffee button for two identical cups

- Removable milk carafe for freshness

ACCESSORIES

- Care Kit

- Descaling Solution

- 30" Trim Kits - M Series

- 30" Trim Kits - E Series

Accessories available through an authorized dealer.
 For local dealer information, visit subzero-wolf.com/locator.



30" TRIM OPTIONS



E SERIES TRANSITIONAL



E SERIES PROFESSIONAL



M SERIES TRANSITIONAL



M SERIES PROFESSIONAL



M AND E SERIES CONTEMPORARY

PRODUCT SPECIFICATIONS

Model	EC24/B
Dimensions	23 1/2"W x 17 7/8"H x 18"D
Weight	80 lbs
Electrical Supply	120 VAC, 60 Hz
Electrical Service	15 amp dedicated circuit
Power Cord Length	6 Feet
Receptacle	3-prong grounding-type

ELECTRICAL

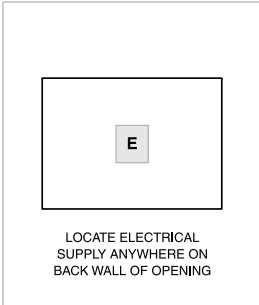

INSTALLATIONS WITH ACCESSORY TRIM Accessory trim may affect overall product dimensions and opening dimensions. Refer to [Reveal](http://subzero-wolf.com/reveal) for more information: subzero-wolf.com/reveal

NOTE: Dimensions in parenthesis are in millimeters unless otherwise specified

DIMENSIONS

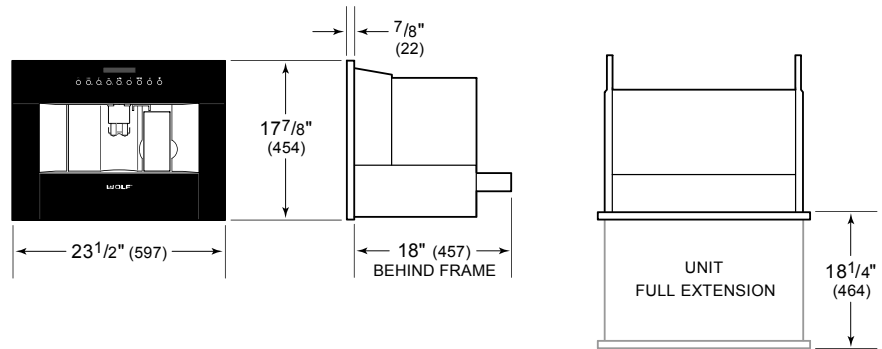

STANDARD INSTALLATION

